

CONTROL MODES NEXT EPSOLUTION

Classic Drive, Master Drive,
Hydraulic Cabin and Electric Cabin

PALFINGEREPSILON.COM



**HAVE YOU CHOSEN YOUR
CONTROL MODE?**



STRIPPED BACK TO THE ESSENTIALS

CLASSIC DRIVE – THE LIGHTWEIGHT ALTERNATIVE FROM PALFINGER EPSILON

CONTROL MODES

Precise, easy-to-operate crane control system hinged directly on valve.



JM

Two mechanical joysticks, two mechanical foot pedals directly mounted on valve



4 LM

Four mechanical levers, two mechanical foot pedals



5 LM

Five mechanical levers, one mechanical foot pedal

STABILIZER CONTROL

Secured by the top seat against unintended activation.

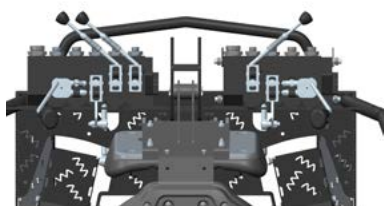

Three levers hydraulically controlled from the top seat



1FM

An additional free function offered by Classic Drive – operation via a directly mounted lever

HIGHLIGHTS

- Lightweight, robust, tried and tested and reliable
- Distance of seat bucket to controls can be adjusted; seat can be accessed from both sides
- High-quality control valves in single and double-circuit operation for constant pump operation
- EN12999-compliant CE equipment for timber applications (CEH) and recycling applications including high-performance stability control (CERM) available
- External hose guide on crane column without rotary distributor
- Halogen lights as standard; LEDs optional
- Emergency stop, seat contact switch and operating hour counter on top seat

ALIGNMENT OF TOP SEAT

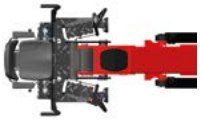

HM

Rear top seat mounted centrally on column



HVL

Turned 16° to the left by means of adjustment wedges



HVR

Turned 16° to the right by means of adjustment wedges

COMFORT PACKAGE



CP

With emergency stop, lights, hour counter, horn, seat heating, engine start/stop feature, speed +/-, fully cabled up to electro box at crane base



SAFE IN THE SADDLE

MASTER DRIVE - THE COMFORT TOP SEAT FROM PALFINGER EPSILON

MULTI-FUNCTIONAL ARMREST

All controls are within reach with the multi-functional armrest.



Changeover switch between crane and stabilizer operation unit, emergency stop, ON/OFF control for stabilizer and ON/OFF control of 1F/2F if selected.



Light control, engine start/stop feature, speed +/-, HPLS ON/OFF if selected, seat heating and signal horn

HIGHLIGHTS

- Comfortable and ergonomically designed for maximum productivity
- All hydraulic functions routed within crane column via rotary distributor; no hose package positioned on the exterior of the column
- High-quality control valves in single and double circuit operation for constant pump operation as well as single-circuit design for variable pump operation as six-section version mounted on crane column
- Crane operation via ergonomically shaped and servo controlled joysticks
- EN12999-compliant CE equipment for timber applications (CEH) and recycling applications including adaptive high-performance stability control in "Light" (CERHL) or "Full" (CERH) available
- Stabilizer control can be switched ON/OFF from the top seat via electric buttons integrated into the armrests. PVG32 stabilizer valve mounted on slewing cylinder under protective cover
- Comfort package consisting of folding GRAMMER seat with mechanical suspension, adjustable armrests, seat heating, engine start/stop feature, speed +/- (fully cabled up to crane base)
- Seat support can be folded into transport position via pneumatic cylinders, actuated by an electric button on the crane base
- Cable remote control at crane base for stabilizer (KCA) or main boom, outer boom and slewing crane functions (KCHK) optionally available

CONTROL MODES

Servo controlled joysticks make it easy to work precisely.



JH

Two hydraulic joysticks, two pedals



4LH

Four hydraulic linear levers, two pedals



5LH

Five hydraulic linear levers, one pedal



EPSHOOD

The newly developed crane operator protection EPSHOOD ensures optimum protection during work. The folding mechanism and technical thermoplastic keep wind, rain and sun away from the operator at all times, ensuring maximum comfort every time.

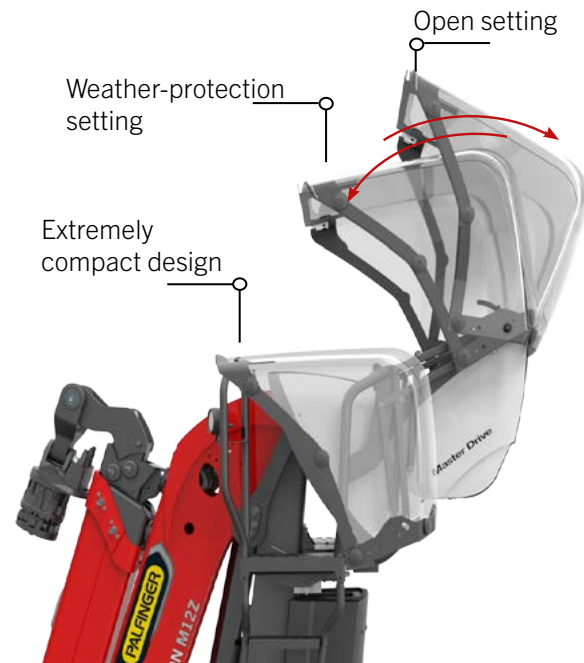

HORIZONTALLY AND VERTICALLY AIR SUSPENDED COMFORT TOP SEAT

The comfortable, ergonomically shaped seat from the house of GRAMMER including seat heating and weight adjustment options.



MAXIMUM COMFORT AS WELL AS MAXIMUM PROTECTION

CAH - CABIN WITH HYDRAULIC SERVO CONTROL FROM PALFINGER EPSILON

CABLE REMOTE CONTROL

Operate the crane comfortably and safely from the crane base.



KCA

Cable remote control at crane base for all stabilizer functions; available with dead man's switch and emergency stop.



KCH

Cable remote control at the crane base for all stabilizer and crane functions (apart from cabin lift); available with dead man's switch and emergency stop. Changeover between stabilizer and crane operation unit included; mode of operation indicated via LEDs.



HIGHLIGHTS

- All hydraulic functions routed within crane column via rotary distributor
- External hose package on column with electric cables
- High-quality control valves in single and double circuit designs for constant pump operation as well as single-circuit design for variable pump operation as seven-section version mounted on crane column
- Cabin lift can be elevated 1100 mm. ON/OFF control via buttons in cabin
- Stabilizer control can be switched ON/OFF via electric buttons on the cabin operator terminal. PVG32 stabilizer valve mounted on slewing cylinder under protective cover
- Comfort package consisting of seat with pneumatic suspension, RDS radio with CD player, two loudspeakers, interior lighting, windscreen wipers, protective windscreen shutter, adjustable armrests, seat heating, engine start/stop feature, speed +/- (fully cabled up to crane base) included
- Three LED lights on cabin as standard
- Cabin painted with RAL9003; side door painted with RAL9005
- Front and side door as standard
- Tamtron Standard (TTS) and Tamtron Timber (TTT) weighing system available
- HYDAC vibration damper (SD) for main boom and slewing available
- Yellow warning light on cabin roof (WLG) available
- Water-heating system (WH) with external water hose on column or WEBASTO diesel heating system (DH)
- Air-conditioning system (AC) operated via additional hydraulic function available in combination with variable pump
- One (1F) or two (2F) additional hydraulic functions available at stabilizer valve. ON/OFF operation from the cabin

CONTROL MODES

Servo controlled joysticks make it easy to work precisely.



JH
Two servo controlled joysticks



Each with two servo controlled fast pedals



4LH
Four hydraulically piloted joysticks

OPERATOR TERMINAL

All functions at a glance clearly arranged in the operator's field of vision.

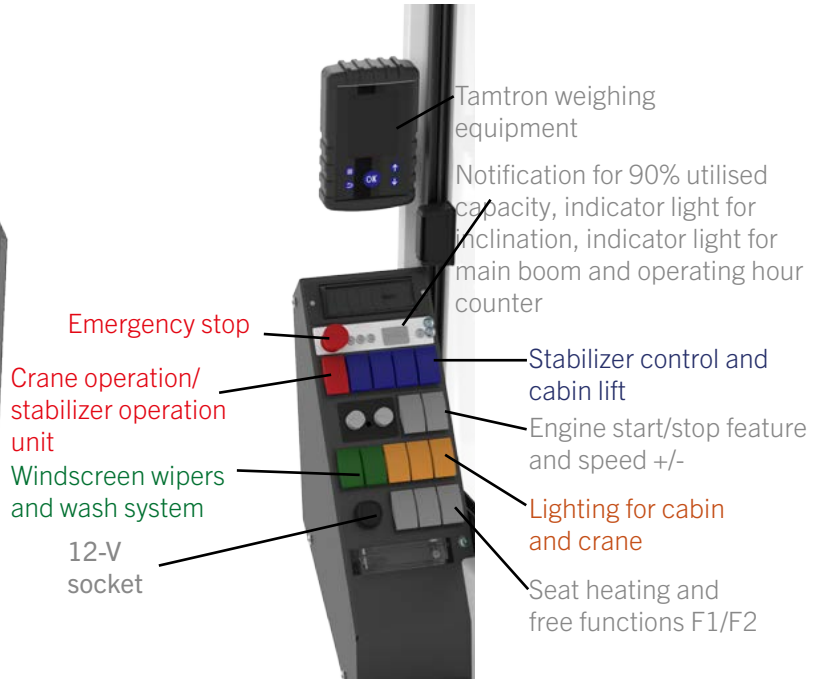

HORIZONTALLY AND VERTICALLY AIR SUSPENDED COMFORT TOP SEAT

The comfortable, ergonomically shaped seat from the house of GRAMMER including seat heating and weight adjustment options.



FOR THE HIGHEST DEMANDS AND MAXIMUM PROTECTION

CAE - CABIN WITH ELECTRONIC CONTROL FROM PALFINGER EPSILON

OPERATOR TERMINAL

All functions at a glance clearly arranged in the operator's field of vision.

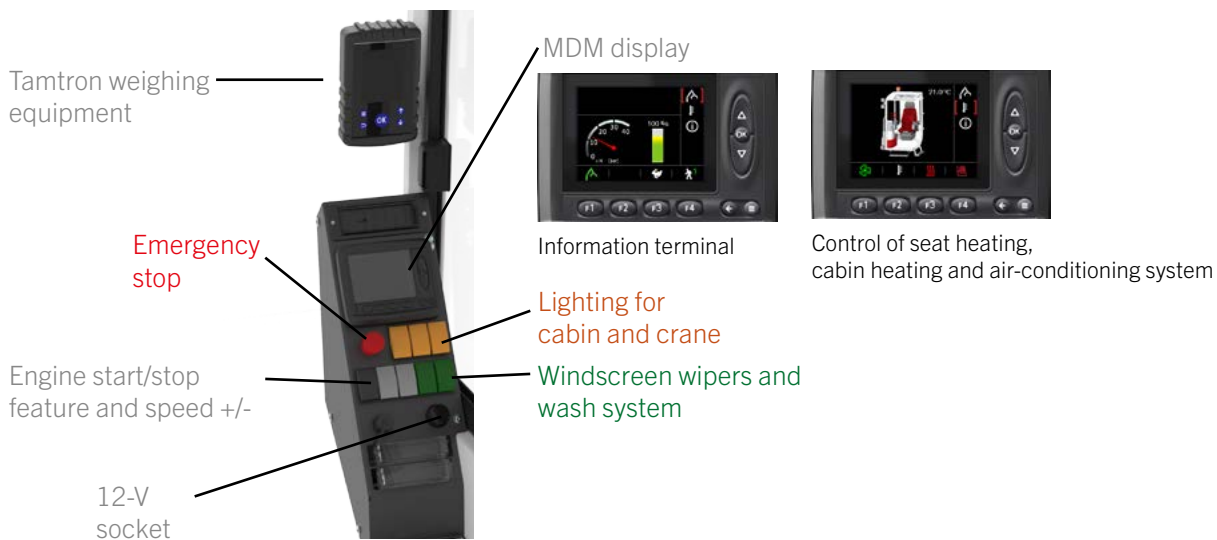

HIGHLIGHTS

- All hydraulic functions routed within crane column via rotary distributor
- External hose package on column with electric cables
- High-quality control valve combination consisting of Parker L 90LS and K220 in single-circuit design for variable pump operation as seven-section version mounted on crane column.
- Cabin lift can be elevated 1100 mm. ON/OFF control via joysticks in cabin
- Stabilizer control can be switched ON/OFF via joysticks in cabin. PVG32 stabilizer valve mounted on slewing cylinder under protective cover
- Comfort package consisting of seat with pneumatic suspension, RDS radio with CD player, two loudspeakers, interior lighting, windscreen wipers, protective windscreen shutter, adjustable armrests, seat heating, engine start/stop feature, speed +/- (fully cabled up to crane base) included
- Three LED lights on cabin as standard
- Cabin painted with RAL9003; side door painted with RAL9005
- Front and side door as standard
- HYDAC vibration damper for main boom and slewing as standard
- Tamtron Standard (TTS) and Tamtron Timber (TTT) weighing system available
- Yellow warning light on cabin roof (WLG) available
- Water-heating system (WH) with external water hose on column or WEBASTO diesel heating system (DH)
- Air-conditioning system (AC) operated via additional hydraulic function available in combination with variable pump
- One (1F) or two (2F) additional hydraulic functions available at stabilizer valve. ON/OFF operation via joysticks in cabin
- Cabin lift position monitoring system (KLP) available

CABLE REMOTE CONTROL

Operate the crane comfortably and safely from the crane base.



Cable remote control at crane base for all stabilizer and crane functions (except for cabin lift); available with dead man's switch and emergency stop. Changeover between stabilizer and crane operation unit included; mode of operation indicated via LEDs.

CONTROL MODES

Electro-hydraulic joysticks for effortless work

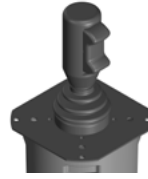

JEM
Two electric "Mini" joysticks

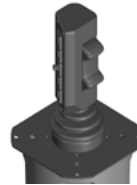

JEMP
Two electric "Mini" joysticks with additional ON/OFF buttons



JEL
Two electric "Large" joysticks



JELP
Two electric "Large" joysticks with additional ON/OFF buttons



HORIZONTALLY AND VERTICALLY AIR SUSPENDED COMFORT TOP SEAT

The comfortable, ergonomically shaped seat from the house of GRAMMER including seat heating and weight adjustment options.



EQUIPMENT

		HCDH		HMDH				CAH			CAE	
		CLASSIC		MASTER DRIVE								
		1K-F130M	2K-F130M	1K-R290	2K-R290	1K-F130	2K-F130	LS-K220	1K-R290	2K-R290	LS-K220	LS-K220E
NORM												
CEH	Safety package for timber loaders	<input type="checkbox"/>			<input type="checkbox"/>				<input type="checkbox"/>			<input type="checkbox"/>
CERM	CE "Mini" package for recycling cranes	<input type="checkbox"/>										
CERHL	CE "Light" for recycling loaders											
CERH	CE package for recycling loaders			<input type="checkbox"/>				<input type="checkbox"/>				
CONTROLS												
JM	2 mechanical joysticks, 2 mechanical foot pedals directly mounted on the valve	<input type="checkbox"/>										
4LM	4 mechanical levers, 2 mechanical foot pedals directly mounted on the valve	<input type="checkbox"/>										
5LM	5 mechanical levers, 1 mechanical foot pedal directly mounted on the valve	<input type="checkbox"/>										
JH	2 hydraulic servo controlled joysticks, 2 servo controlled foot pedals					<input type="checkbox"/>			<input type="checkbox"/>			
4LH	4 hydraulic servo controlled levers, 2 servo controlled foot pedals					<input type="checkbox"/>			<input type="checkbox"/>			
5LH	5 hydraulic servo controlled levers, 1 servo controlled foot pedal					<input type="checkbox"/>						
JEM	2 electric Joysticks with 3 proportional functions, model "Mini"											<input type="checkbox"/>
JEMP	2 electrical Joysticks with 3 proportional functions and additional ON/OFF buttons, model "Mini"											<input type="checkbox"/>
JEL	2 electrical joysticks with 3 proportional functions, model "Large"											<input type="checkbox"/>
JELP	2 electrical joysticks with 3 proportional functions and additional ON/OFF buttons, model "Large"											<input type="checkbox"/>
HYDRAULICS												
1K-F130M	Parker F130CF control valve for single circuit operation for Classic Drive top seat, prepared for constant pump operation	<input type="checkbox"/>										
2K-F130M	Parker F130CF control valve for double circuit operation for Classic Drive top seat, prepared for constant pump operation		<input type="checkbox"/>									
1K-R290	Nordhydraulic RSM290 control valve for single circuit operation and hydraulic pilot controls			<input type="checkbox"/>					<input type="checkbox"/>			
2K-R290	Nordhydraulic RSM290 control valve for double circuit operation and hydraulic pilot controls				<input type="checkbox"/>					<input type="checkbox"/>		
1K-F130	Parker F130CF control valve for single circuit operation and hydraulic pilot controls, prepared for constant pump operation					<input type="checkbox"/>						
2K-F130	Parker F130CF control valve for double circuit operation and hydraulic pilot control, prepared for constant pump operation						<input type="checkbox"/>					
LS-K220	Parker control valve for single circuit operation, ATTENTION: only in combination with SD							<input type="checkbox"/>			<input type="checkbox"/>	
LS-K220E	Parker control valve for single circuit operation and electric controls, prepared for variable pump operation.											<input type="checkbox"/>
CONTROL STAND POSITION												
HM	Rear top seat central mounted on column	<input type="checkbox"/>				<input type="checkbox"/>						
HVL	Rear top seat central mounted on column, by adjustment wedges 16° turned to the left Attention: not available in combination with TGR / TUR and KFS!	<input type="checkbox"/>				<input type="checkbox"/>						
HVR	Rear top seat central mounted on column, by adjustment wedges 16° turned to the right Attention: not available in combination with TGL / TUL and KFS!	<input type="checkbox"/>				<input type="checkbox"/>						
250 FURTHER OPTIONS												
N7	7° safety shut down with a tilt sensor ATTENTION: Only required in Germany for CE timber!						<input type="checkbox"/>					
CP	comfort package with seat heating, engine Start/Stop, RPM +/-, complete wired till electric box on crane base	<input type="checkbox"/>										
1FM	one additional free function on CLASSIC DRIVE top seat, operation by directly mounted lever	<input type="checkbox"/>										
1F	One additional free function on PVG32 control valve, operation by ON/OFF buttons from control stand								<input type="checkbox"/>			
2F	Additional second function on PVG32 stabilizer valve, operation by ON/OFF buttons from control stand									<input type="checkbox"/>		
KCA	Cable control for stabilizer on crane base by ON/OFF buttons					<input type="checkbox"/>			<input type="checkbox"/>			
KCHKS	Cable control for main boom, knuckle boom, slewing on the crane base by ON/OFF buttons					<input type="checkbox"/>			<input type="checkbox"/>			
KCH	Cable control for CAH cabin for all functions (except cabinlift) on crane base with ON/OFF buttons								<input type="checkbox"/>			
KFS	EPSHOOD automatic tiltable operator protection.					<input type="checkbox"/>						
LED	LED spot lights (2x top seat, 2x spot lights knuckle boom), 2600 Lumen	<input type="checkbox"/>				<input type="checkbox"/>						
LED 2	2 x LED spotlights on knuckle boom. ATTENTION: only for cabine cranes!										<input type="checkbox"/>	
SD	Hydac swinging dampers for main cylinder and slewing					<input type="checkbox"/>		!	<input type="checkbox"/>	!		
SLP	Substitute hose package								<input type="checkbox"/>			
TTSW	Tamtron Standard Weather, weighing device for MASTER DRIVE. Handling by additional button on joystick/ lever.					<input type="checkbox"/>						
ITS	Tamtron Standard weighing device for cabin. Handling via foot pedal on CAE.										<input type="checkbox"/>	
ITT	Tamtron Timber weighing device for cabine. Handling by footpedal on CAE. Handling via additional button on joystick/lever on CAH										<input type="checkbox"/>	
WH	Water heating for crane operator cabin. ATTENTION: heated hose routed on exterior of crane column										!	
DH	Webasto Diesel heating for crane operator cabin										!	
KLP	Cabin lift monitoring for crane operator cabin.											<input type="checkbox"/>
AC	Air condition for cabin cranes. Air condition is powered by additional hydraulic function.											<input type="checkbox"/>
AT2	Additional second step for access into cabin											<input type="checkbox"/>
CSSE	Special sequence control for Scandinavia (Function grab & telescopic arm reversed)											<input type="checkbox"/>
WLG	Yellow warning light on cabin roof										<input type="checkbox"/>	

Only equipment relevant for the respective control mode is shown

SLEWING RADIUS

Classic Drive (HCDH)

L-crane

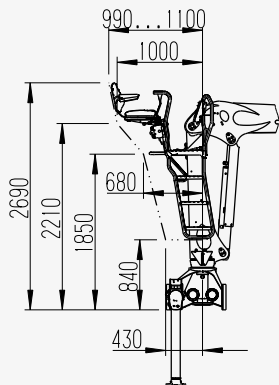

Z-crane

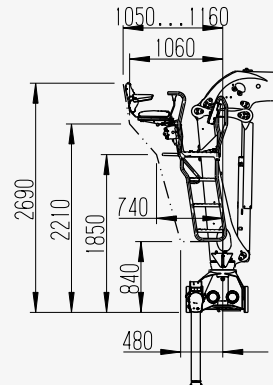

Master Drive (HMDH)

L-crane

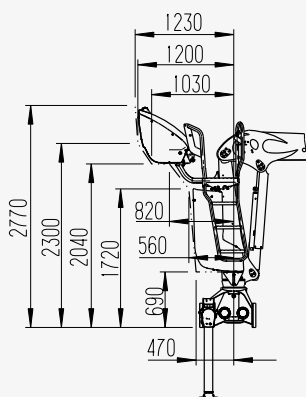

Z-crane

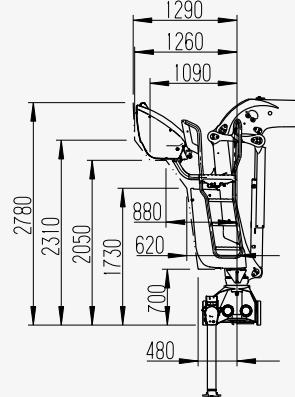

Cabin (CAH & CAE)

L-crane

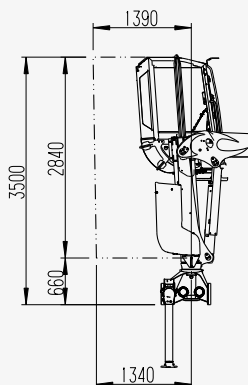

Z-crane

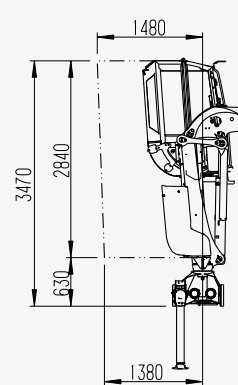

EPSILON KRAN GMBH

**Christophorusstraße 30
5061 Elsbethen-Glasenbach | Austria
+43 662 / 629548 - 0
epsilon@palfinger.com
www.palfingerepsilon.com**

PR085 is meant for international use. The availability of some models and the model and special equipment may vary from country to country. EPSILON reserves the right to change design or technical specification at any time without prior notice. Any changes would not be applied retrospectively to previously sold units. Information, description and illustrations are correct at time of going to print, but may also be changed without prior notice. Illustrations may show certain country specific executions and special equipment, and therefore may not be complete standard execution. Measure data without obligation. Lifting capacity presentations are standard illustrations and don't correspond the optimize boom position, where the maximum lifting capacity can be reached.